

# Broadband Loop Antenna for DCS-1800/IMT-2000 Mobile Phone Handsets

R. L. Li, E. M. Tentzeris, J. Laskar, *Member, IEEE*, V. F. Fusco, and R. Cahill

**Abstract**—A rectangular loop antenna is proposed for DCS-1800 and IMT-2000 mobile phone handsets. By introducing a small gap in the wire loop, an impedance bandwidth of 24% can be achieved. The antenna mounted on a metal box is simulated using the FDTD method. It is found that the introduction of a small gap also results in a radiation pattern with desirable polarization independence and a reduced gain in the direction of the user's head. The simulated and measured results are presented.

**Index Terms**—Broadband antennas, DCS-1800, handsets, IMT-2000, loop antennas.

## I. INTRODUCTION

LOOP ANTENNAS can be used in mobile phone handsets [1]. However, a conventional wire loop antenna usually has a bandwidth for a 2:1 VSWR of less than 10%. In modern mobile communication systems, it is desirable for a handset antenna to operate at a dual-band mode, such as in the Digital Communications System-1800 (DCS-1800: 1710–1880 MHz) [2] and the International Mobile Telecommunications-2000 (IMT-2000: 1885–2170 MHz) [3] services. In this letter, we propose a new broadband rectangular loop antenna whose bandwidth covers the DCS-1800 and IMT-2000 bands. By introducing a small gap in the wire loop, the impedance bandwidth of the antenna can be increased to more than 24%. It is also found that when mounted on a metal box, the antenna shows a radiation pattern with a reduced gain in the direction of the user's head, which is desirable for reduction in the spatial peak specific absorption rate (SAR) [4].

## II. ANTENNA STRUCTURE AND RESULTS

The antenna structure is based around a 30 mm × 14 mm rectangular wire loop but with a 1-mm gap near a corner. The wire loop antenna is mounted vertically on a metal box with a dimension of 90 mm × 50 mm × 20 mm to simulate a mobile phone handset, as illustrated in Fig. 1. The mounted antenna structure is simulated using the finite-difference time-domain (FDTD) method. The FDTD cell size is 1 mm × 2 mm × 3 mm and five

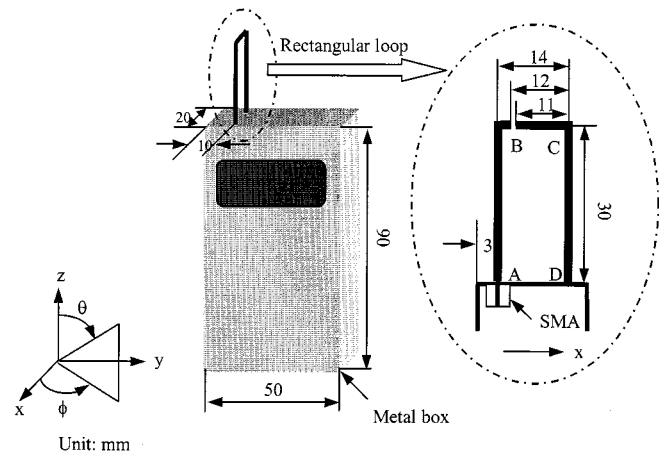

Fig. 1. Loop antenna mounted on a metal box.

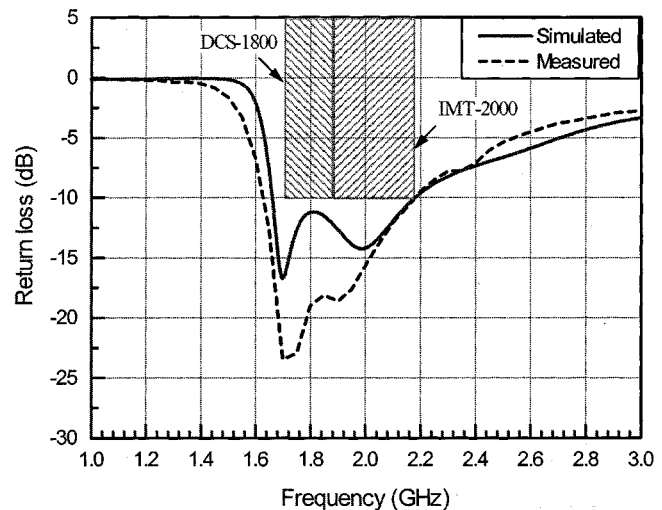

Fig. 2. Simulated and measured return loss.

uniaxial perfectly matched layer (UPML) cells are used to truncate the FDTD computational domain. In experiment, the loop wire was made of an etched copper strip with a rectangular section of width  $w = 2$  mm and thickness  $t = 17.5 \mu\text{m}$  printed on an RT/duroid 5880 dielectric substrate (thickness = 0.254 mm,  $\epsilon_r = 2.2$ ).

As for the design of the rectangular loop antenna, it is found by numerous numerical simulations: 1) the gap must be located at the top side of the loop and 2) a large enough difference in length between two coupled monopoles (AB and BCD) is essential for the achievement of a desirable impedance bandwidth. Considering the limited width of mobile phone handsets, we

Manuscript received December 20, 2001; revised May 21, 2002. This work was supported by the Yamacraw Design Center, the NSF Career Award under Contract NSF 9964761, the NSF Packaging Research Center, and the U.K. Engineering and Physical Research Council. The review of this letter was arranged by Associate Editor Dr. Shigeo Kawasaki.

R. L. Li, E. M. Tentzeris, and J. Laskar are with the School of Electrical and Computer Engineering, Georgia Institute of Technology, Atlanta, GA 30332-250 USA (e-mail: rlli@ece.gatech.edu).

V. F. Fusco and R. Cahill are with the Department of Electrical and Electronic Engineering, Queen's University of Belfast, Belfast, U.K.

Publisher Item Identifier 10.1109/LMWC.2002.802031.

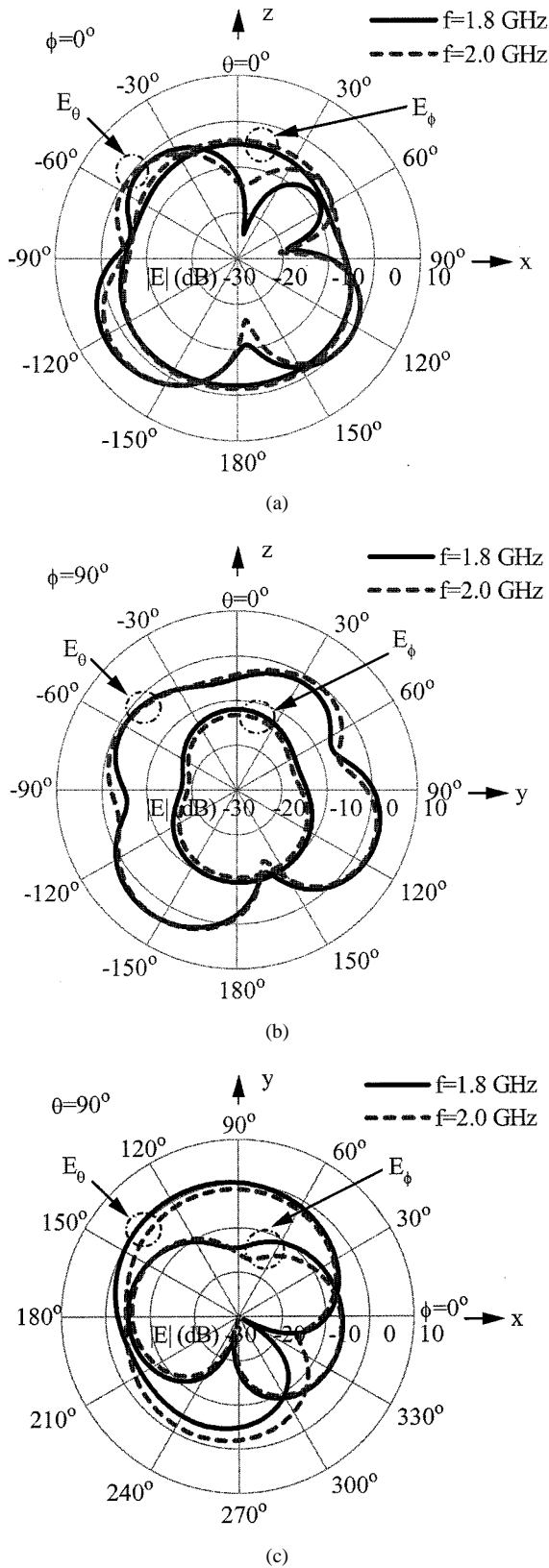

Fig. 3. Simulated radiation patterns for DCS-1800 and IMT-2000 bands (a)  $x-z$  plane, (b)  $y-z$  plane, and (c)  $x-y$  plane.

therefore choose the gap near a corner of the rectangular loop and adjust the total length of the rectangular wire loop to be around 74 mm for covering the DCS-1800 and IMT-2000 bands.

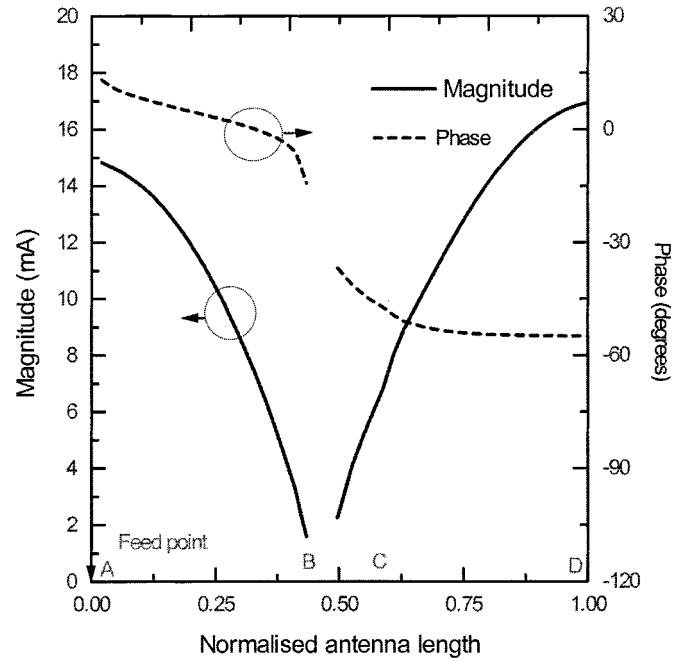

Fig. 4. Current distribution at 2 GHz along the loop.

The initial size of the loop antenna was optimized using the numerical electromagnetic code (NEC V1.1).

The simulated and measured results for the return loss are shown in Fig. 2. Good agreement can be seen. The impedance bandwidth for a 10-dB return loss is about 24%, enough to cover the DCS-1800 and IMT-2000 bands. The reason for the bandwidth increase is due to the combination of two close resonant frequencies: one for the directly excited monopole AB and the other for the coupled monopole BCD.

The simulated radiation patterns at frequencies 1.8 GHz and 2.0 GHz are plotted in Fig. 3. It is easy to see that there is a similar radiation pattern in the two bands. Note that there is a considerable increase in  $E_\phi$  component, which is quite different from a conventional loop antenna. This pattern is helpful in improvement of the polarization independence on account of the undefined orientation of a handset mobile [5]. It is also interesting to note that the  $E_\theta$  pattern has a nearly isotropic radiation characteristic with a notch (about  $-10$  dBi) in the  $+x$  direction. This is a strongly desired pattern for a mobile phone handset to reduce the SAR in the user's head. The reason for the notched  $E_\theta$  pattern can be understood by checking the current distribution on the loop, which is shown in Fig. 4. We can see that the current phase on side dc is about  $60^\circ$  ahead of that on side AB (note that in Fig. 4 the current is assumed to flow from C to D). As a result, the  $E_\theta$  pattern will tilt toward side AB, i.e., the  $-x$  direction.

### III. CONCLUSION

It was demonstrated that a rectangular loop can serve as a broadband antenna. By introducing a small gap in the wire loop, the antenna achieves an impedance bandwidth of 24%, which is enough to cover the DSC-1800 and IMT-2000 bands. The loop antenna mounted on a metal box is measured and

simulated using the FDTD method. It was shown that the antenna provides a radiation pattern with enhanced polarization independence and a reduced gain in the direction of the user's head.

#### REFERENCES

- [1] K. D. Katsibas, A. Balanis, P. A. Tirkas, and C. R. Birtcher, "Folded loop antenna for mobile hand-held units," *IEEE Trans. Antennas Propagat.*, vol. 46, pp. 260–266, Feb. 1998.
- [2] C. R. Rowell and R. D. Murch, "A capacitively loaded PIFA for compact mobile Telephone handsets," *IEEE Trans. Antennas Propagat.*, vol. 45, pp. 837–842, May 1998.
- [3] Y. J. Wang, C. K. Lee, and Y. B. Gan, "Design of small and broad-band internal antennas for IMT-2000 mobile handsets," *IEEE Trans. Antennas Propagat.*, vol. 49, pp. 1398–1403, Aug. 2001.
- [4] J. Fuhl, P. Nowak, and E. Bonek, "Improved internal antenna for hand-held terminals," *Electron. Lett.*, vol. 30, no. 22, pp. 1816–1817, 1994.
- [5] J. Rasinger, E. Bonek, V. Lauskancan, and A. Scholtz, "The internal antennas in new personal communications," in *Proc. ITU Tech. Symp. Integration, Interoperation and Interconnection: The Way to Global Services*, vol. 2, 1991, pp. 195–199.