

"Smart Shoe": an autonomous inkjet-printed RFID system scavenging walking energy

Giulia Orecchini*

Department of Electrical Engineering
University of Perugia,
Perugia, Italy
giulia.orecchini@diei.unipg.it

Li Yang

Texas Instruments,
Dallas, TX, 75243, U.S.A.
liyanggt@gmail.com

Manos M. Tentzeris,

Department of Electrical and Computer
Engineering,
Georgia Institute of Technology,
Atlanta, USA
emmanouil.tentzeris@ece.gatech

Luca Roselli

Department of Electrical Engineering
University of Perugia,
Perugia, Italy
luca.roselli@diei.unipg.it

Abstract— In this research the embodiment of wearable battery-free, active, paper printed RFID tags with energy scavenging capabilities is presented. Extraction of electrical energy from human body movement is obtained by a piezoelectric energy scavenger powering up an active RFID tag.

Keywords—component; formatting; style; styling; insert (key words)

I. INTRODUCTION

Until today, as electronic became smaller and required less power, ubiquitous computing's dream of wireless nodes is accompanied by the nightmare of battery replacement and disposal. Overcoming this trend requires moving to another energy source – harvesting energy from ambient environment.

As the entire energy consumption of the RF communications unit must be scavenged from the human activity, the choice of energy scavenging technology is crucial. Human body is an under-estimated energy source which is continuously generating energy outputs. For example, it has been shown that the heat flow generated by the human body creates a power density of about 20 mW/cm² on average. Ramsay and Clark [1] found that output power generated from blood pressure at 100 mmHg is about 0.93 watts. Paul Mitcheson [2] has proposed several forms of vibration-driven MEMS microgenerator using the motion of the human body to produce power at the scale of tens of microwatts. Thad Starner's investigation [3] analyzed different kinds of human activities and found that the heel strike during walking is a plentiful and readily tapped source of waste energy. Starner estimated that average 67 watts of power are generated in the heel movement of a 68 kg person walking at a brisk pace. Admittedly, scavenging most of that energy unobtrusively would be impossible. But even a small percentage of it would

provide enough power to operate many of the body-worn systems on the market today.

The attention for wearable electronics increased in the past few years especially because of the property of enabling people to carry their personal wireless body-area network providing medical, lifestyle, assisted living, mobile computing and tracking functions along with identification and sensing features [4]. For wearable electronics, besides the realization of increasingly sophisticated batteries [5], we observe the trend of scavenging and storing energy from human activity [6]. In this project an RFID active tag has been developed. Autonomy of the system has been obtained by realizing an energy scavenger able to provide to the RFID tag enough energy to supply the device for the time needed to transmit enough packets of information bits through the RFID reader. To this scope, a piezoelectric pushbutton has been embedded in a shoe to scavenge energy from human walking strike. This energy is then collected by a simple electronic circuit based on the shelf components and used to empower the RFID transmitter. Attentions have been paid to both the performance and the aesthetic appearance of the antenna. The requirement of wearable electronics leads to a considerable design challenge in terms of antenna design technique.

II. SHOE-MOUNTED ANTENNA DESIGN

The antenna needs to be conformal to fit in the shoe's garment where no flat surface can easily be found, unobtrusive, low-profile and comfortable to wear, therefore traditional rigid antennas are not applicable. Moreover the 69 cm wavelength associated to the UHF RFID band allocation at 433 MHz along with the shoe mounting constrains, require the antenna be far smaller than the wavelength. Additionally the antenna needs to have robust performance in the presence of

human body tissues because a ground plane can be hardly incorporated into the shoe so the detuning effect of human tissue must be accounted for in the antenna design.

As a proof-of-concept a design that uses a company logo is proposed as a shoe-mounted antenna example; the logo is supposed to be stuck on the shoe so that no extra space is needed for the antenna. The circuit and the antenna were inkjet printed together on the flexible substrate and Epo-Tek silver epoxy was applied to fix the discrete components on the substrate. A photograph showing the integration of the assembled prototype with the logo antenna is illustrated in Figure 1. The antenna structure (Figure 2(a)) intrinsically works as a dipole, the center feeding is located in the back of the shoe and it will be connected to the output port of the RF

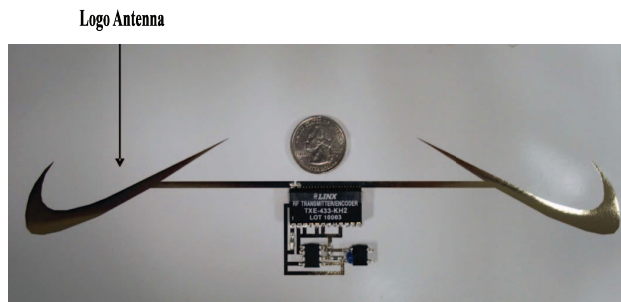
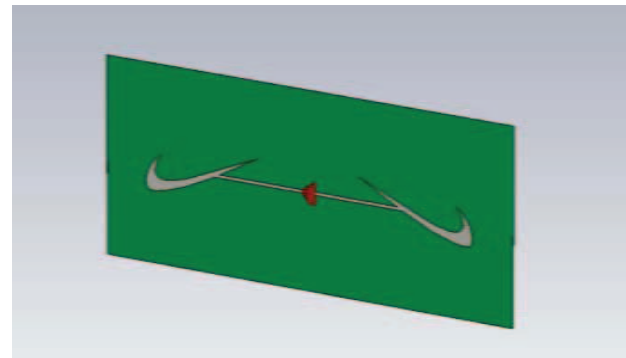

Fig.1. Assembled prototype showing the key components of the RFID tag.

transmitter easily embedded and protected in the heel part. The “radiating logo” appears on both sides of the shoe and is connected to the central feeding by strip lines; at this level of the development the antenna is inkjet printed by a Dimatix printer on hydrophobic paper substrate [7].

A Rohde & Schwarz ZVA8 VNA was used to measure the antenna performance; the measured and simulated return loss together with the far field radiation pattern of the RFID tag antenna before being mounted on the shoe is shown in Figure 2(b)-(c). The measured BW of $V_{SWR}=2$ extends from 419 MHz to 467 MHz, which is around 10.8% fractional BW. The radiation pattern is almost omnidirectional in the Phi plane with an expected null along the main direction of the equivalent dipole. At 416 MHz a gain around 2 dBi is observed. In Figure 3(a) the shape of the bent logo is shown; simulations have been carried out with CST Microwave Studio. The return loss in the case of bent antenna located in air is shown in Figure 3(c). It can be seen that no frequency shift is caused by the bending, while the radiation diagram is positively altered: the transmission nulls disappeared and the radiation diagram performs actually omnidirectionally. To study the effect of the human foot on the return loss and far field radiation pattern of the logo antenna, a human electromagnetic model, the “CST Voxel family” has been used. The comparison between simulations and measurements is shown in Figure 4(c). From the results shown in Figure 3 and 4 one can see that the presence of the human tissue causes a lower shift in the resonance frequency from around 430

MHz to 400 MHz; this is because the tissue works partially as a dielectric substrate for the antenna with a dielectric constant higher than the air that is the case of the sole bent paper antenna without foot behind it. The radiation pattern is shown in Figure 4(b); it can be observed that the presence of the foot increased slightly the directivity in the heel part of the shoe where the RFID tag and the central feeding lines of the antenna is placed. A slight variation of the radiation diagram is observed with the onset of a sort of main lobe with a directivity of 2.66 dBi; by the way, the overall omnidirectional behavior of the structure is retained.



(a)

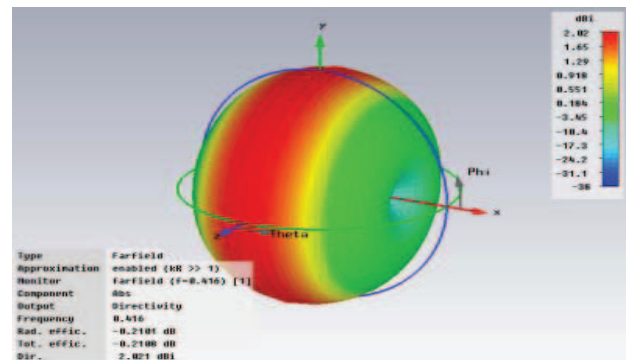

(b)

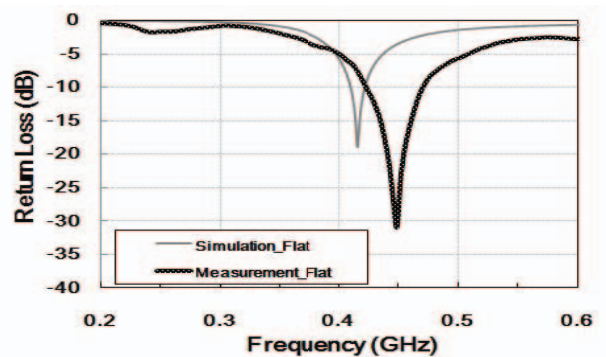

(c)

Fig. 2. Measured and simulated return loss (c) and far field radiation pattern (b) of the logo antenna (a) before mounting on the shoe.

I. SYSTEM DESIGN AND IMPLEMENTATION

The block diagram of the active RFID tag together with the assembled prototype showing the key components packaged

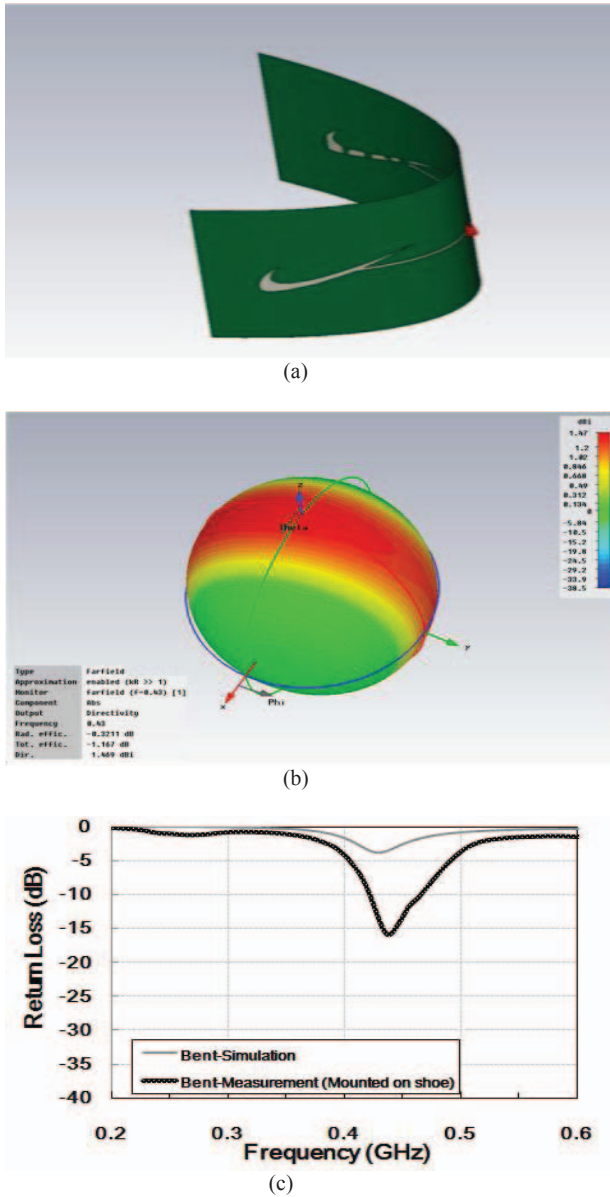

Fig. 3. Measured and simulated return loss (c) and far field radiation pattern (b) of the logo antenna bent (a).

on an organic flexible substrate is shown in Figure 1; the main components of the system are the power-generator/energy-conversion device, the energy storage device, the power regulator circuit and the RF transmitter that can broadcast the TAG ID and the stored information.

A piezoelectric pushbutton has been selected as a good compromise among compactness, simplicity and cost of

specific energy (J/volume).

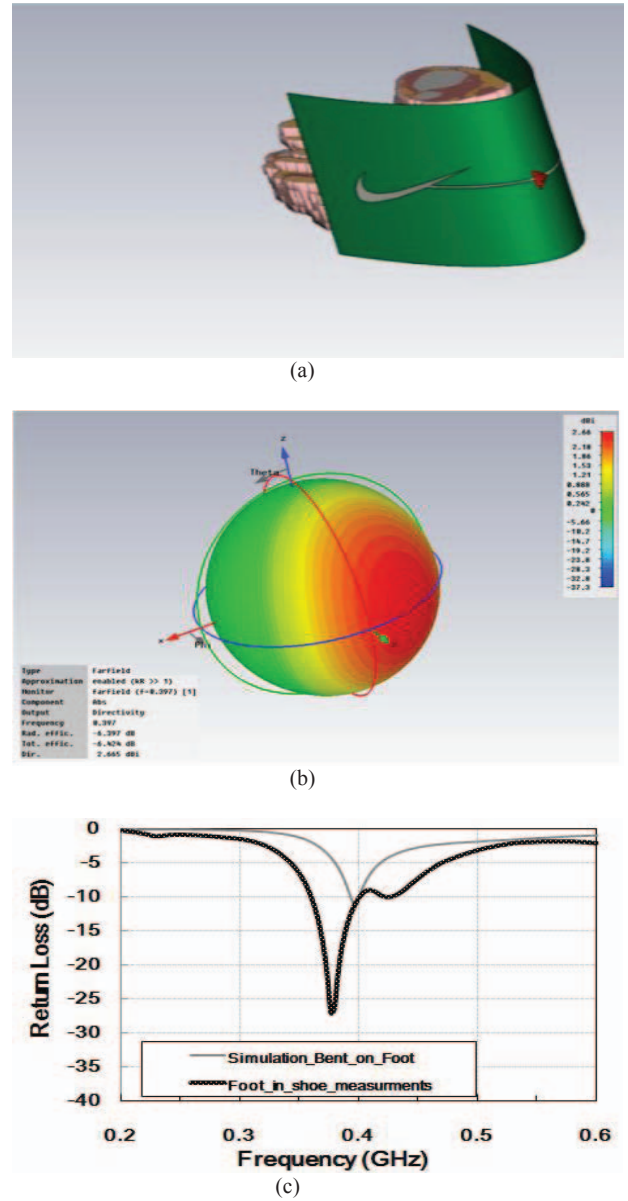

Fig. 4. Measured (foot in worn shoe) and simulated return loss of the logo antenna (electromagnetic model of foot).

When the pushbutton is pressed an inner spring is compressed and when the pressure exceeds a fixed threshold, the spring-loaded hammer will be released to deliver the dynamic mechanical force to the piezoelectric component. Once the hammer strikes the piezoelectric element, a pressure wave is generated and reflected few times between the hammer and the element, creating a mechanical resonance [8].

Consequently the output voltage that is generated will follow similarly to an AC signal course depending on the

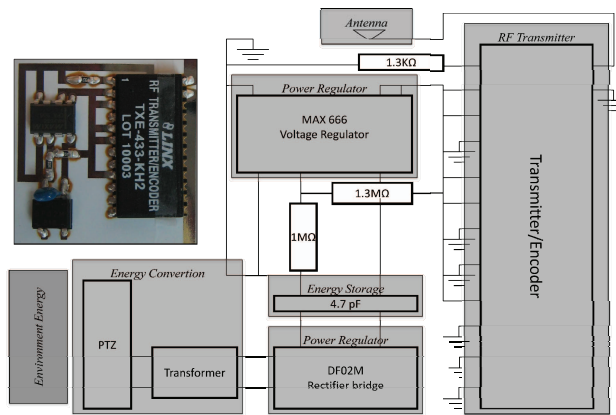

Fig. 1. Photograph of the assembled prototype showing the key components packaged on an organic flexible substrate and block diagram of the active RFID tag driven by the energy harvesting unit.

dynamic polarization of the element. The signal out of the piezoelectric element is high voltage and low current; therefore, since this RF circuitry requires lower voltages at higher currents, a step-down transformer is used for better impedance matching to the following circuitry. Typically an RF transmitter takes tens of milliseconds to transmit one complete word while the piezoelectric push button harvests energy in a transient time; therefore an energy storage device needs to collect the electrical energy and to provide it to the transmitter even when the external power source is temporarily unavailable. The device that was chosen for energy storage is a 4.7 μF tank capacitor and an AC-DC full wave diode bridge rectifier is used while a DC linear regulator is added to adapt the DC voltage across the capacitor to 3 V. A MAX666 low-dropout linear regulator, providing a stable 3 V supply until the tank capacitor's charge is selected. Figure 6 shows the pushbutton embedded on the self-powered RFID shoe.



Fig. 6. Self-powered RFID shoes with mounted electronics.

As seen in Figure 9, roughly 28 ms after the strike, the regulator becomes active, providing power to the active TAG circuitry.

It has been calculated that there are about 833 μJ that can be used to power up the tag.

The required time for successful completion of the RFID

ID broadcasting is 50 ms. By setting the RF output power at -4 dBm level through an external resistor the total circuit energy consumption has been calculated to be approximately 9 mW for 50 ms, totaling 450 μJ . The power scavenging circuit thus produces enough power for this application.

As shown in the figure, the regulated DC voltage from the linear regulator is enough to power up the tag for over 60 ms, covering at least one complete broadcasting cycle (10-bit ID and 8-bit data) which is 50 ms.

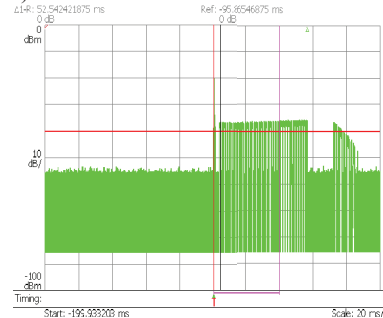

Fig.9. RFID data transmission captured by the RTSA reader antenna

In the present research an energy harvesting circuit designed for piezoelectric pushbutton is proposed and implemented efficiently for a self-powered active RFID tag. This RFID tag is capable of transmitting an 18-bit digital word information using the mechanical force energy harvested from the heel striking. The tag antenna design meets the requirements of being conformal, unobtrusive, low-profiling and comfortable to wear.

REFERENCES

- [1] E. Braunwald, Heart Disease: A Textbook of Cardiovascular Machine, Philadelphia.
- [2] P. D. Mitcheson, "Architectures for Vibration-Driven Micropower Generators," *J. Microelectromechanical Systems*, vol. 13, no. 3, pp. 429-440, 2004.
- [3] T. Stamer, "Human Powered Wearable Computing," *IBM System J.*, vol. 35, no. 3 and 4, pp. 618-629, 1996.
- [4] J.Penders, B.Gyselinckx, R. Vullers, etc., "Human++: from technology to emerging health monitoring concept," *5th International Summer School and Symposium on Medical Devices and Biosensor*, pp.94-98, June, 2008.
- [5] C.Townsend, S.Arms, M.Hamel, J.Galbreath, D.Churchill "Thin film battery recharging from micropower energy harvesting sources", *IEEE Conference Proceedings*, 23-28 Feb. 2008.
- [6] N.Shenck, J.Paradiso, "Energy scavenging for mobile and wireless electronics," *IEEE Micro*, vol. 21, pp.30-42, 2001.
- [7] L.Yang, and M.M.Tentzeris, "Design and Characterization of Novel Paper-based Inkjet-Printed RFID and Microwave Structures for Telecommunication and Sensing Applications", *IEEE International Microwave Symposium*, June, 2007.
- [8] Y.Tan, K.Hoe, S.Panda, "Energy harvesting using piezoelectric igniter for self-powered radio frequency wireless sensor", *IEEE International Conference on Industrial Technology*, pp.1711-1716, 2006.