

A Rectifier Circuit Insensitive to the Angle of Incidence of Incoming Waves Based on a Wilkinson Power Combiner

Spyridon Nektarios Daskalakis¹, *Student Member, IEEE*, Apostolos Georgiadis¹, *Senior Member, IEEE*,
George Goussetis¹, *Senior Member, IEEE*, and Manos M. Tentzeris², *Fellow, IEEE*

Abstract—In this paper, a novel high-efficiency, low-cost, and low-complexity RF-to-dc converter was designed for RF energy harvesting in the 2.4-GHz band. The proposed design has two RF inputs and maintains high efficiency over a wide range of incoming incident wave angles. The circuit is based on a Wilkinson power combiner and has two single-diode rectifiers. One rectifier is connected at the combiner's output and collects the energy coming from the two inputs. The second rectifier replaces the isolation resistor of the combiner in order to collect the power that would, otherwise, be dissipated in it. The second rectifier is used for recycling the wasted power when the input signals do not have the same phase. The novel RF-to-dc converter was fabricated using the commercially available components and a low-cost FR-4 substrate. A prototype was designed, and its efficiency was optimized for low-power input levels. The measured system efficiency was 16.2% for in-phase input signals with an available input power of -17 dBm. When the relative phase of input signals varied from 0° to 360° , a variation in efficiency between 15.3% and 22% was observed. For an input power of 3 dBm, the efficiency varies from 26% to 39% between 0° and 360° phase difference.

Index Terms—Internet of Things (IoT), radio-frequency (RF) energy harvesting, radio-frequency identification (RFID), rectifier, Wilkinson divider, wireless power transfer.

I. INTRODUCTION

IN OUR days, radio-frequency (RF) energy harvesting is an attractive way to capture power in conditions where light or wind sources are not available [1]–[4]. Broadcasting RF transmitters, such as cellular networks base stations,

Manuscript received November 14, 2018; revised February 14, 2019; accepted March 13, 2019. Date of publication May 6, 2019; date of current version July 1, 2019. This work was supported in part by the Lloyd's Register Foundation (LRF) and in part by the International Consortium in Nanotechnology (ICON). The work of M. M. Tentzeris was supported in part by the National Science Foundation (NSF) and in part by the Defense Threat Reduction Agency (DTRA). This paper is an expanded version from the 2nd URSI Atlantic Radio Science Conference (URSI AT-RASC), Gran Canaria, Spain, May 28–June 1, 2018. (*Corresponding author: Spyridon Nektarios Daskalakis.*)

S. N. Daskalakis, A. Georgiadis, and G. Goussetis are with the School of Engineering and Physical Sciences, Heriot-Watt University, Edinburgh EH14 4AS, U.K., and also with the Institute of Sensors, Signals and Systems, Heriot-Watt University, Edinburgh EH14 4AS, U.K. (e-mail: sd70@hw.ac.uk; apostolos.georgiadis@ieee.org; g.goussetis@hw.ac.uk).

M. M. Tentzeris is with the School of Electrical and Computer Engineering, Georgia Institute of Technology, Atlanta, GA 30332 USA (e-mail: etentze@ece.gatech.edu).

Color versions of one or more of the figures in this paper are available online at <http://ieeexplore.ieee.org>.

Digital Object Identifier 10.1109/TMTT.2019.2912192

Wi-Fi routers, and frequency identification (RFID) readers, have been rapidly increasing around us, due to the huge development of wireless technologies. In 1964, Brown [5] proposed a system for the transformation of RF power to dc power. In this RF-to-dc converter, an antenna is combined with a rectifier, which consists of one or more diodes in a specific configuration, thus forming a rectenna. One significant limitation in rectenna design is the relatively low available ambient power density level as well as the RF-to-dc power efficiency of the circuit [4], [6]. It remains an engineering challenge on how to capture unused ambient RF energy and use it to supply small sensor nodes, such as radio-frequency identification (RFID) tags [4], [7], [8]. Interest in Internet-of-Things (IoT) low-power sensors powered by RF ambient power or wireless power transmission has increased due to the vision of ubiquitous sensing as a part of 5G mobile networks. Wireless powering in the 2.4-GHz industrial, scientific, and medical (ISM) band can enable applications where a large number of mobile devices with Wi-Fi/Bluetooth transceivers can act as RF sources to power the sensors.

In most 5G industrial visions, the high energy-efficient “Green” performance for 5G systems is pointed out as a necessity both for devices and networks. Consequently, RF energy harvesting seems to be a very promising technique for future 5G “Green” systems. In this case, nearby relays are considered, which include wireless power transfer capabilities together with the RF communication signals. Millimeter-wave (mmWave) signals could deliver both information and energy to the end small devices, such as next-generation RFIDs [9], [10]. Such an RFID device, capable of operating autonomously and with a reading range of tens of meters, would provide a very effective interface point between the IoT and 5G networks [11].

This paper addresses the problem of RF versus dc power combining rectenna array systems. Increasing the number of antennas and, therefore, the effective area available for the collection of RF energy is a straightforward approach in order to increase the total RF energy that is being harvested. Due to the nonlinear nature of the rectifier circuit, however, when the RF energy that is being available to the individual rectenna element is very small, the RF-to-dc conversion efficiency of the rectifier is also very small leading to a nonoptimal performance. Therefore, not only the overall number of rectenna

elements but also the RF power available to each element is important in order to maximize the system efficiency and ultimately the dc output power. As a result, one might first consider rectenna elements where one rectifier is connected to an antenna array, thereby achieving the superposition of RF energy before the RF-to-dc conversion. For example, in [12], the concept of an $N \times N$ staggered pattern charge collector (SPCC) is described in order to achieve maximum energy-harvesting efficiency. Using the above-mentioned consent, more energy harvesters and, thus, more diode elements are used in order to cover a wideband area. Another disadvantage of this topology is that the superposition of RF energy corresponds to directive antenna elements and one is not able to harvest RF energy coming from different angular directions but only from selected angular directions where the antenna array gain is maximized.

One way around this problem is to employ beam-steering architectures, but such systems consume energy in steering the antenna beam, and therefore, one needs to take into account the amount of energy spent in the beam-steering process in order to compute the overall RF-to-dc conversion efficiency of the system. A different approach is to design a subarray topology where each subarray is pointed to a fixed but different angular direction. This way one achieves high efficiency at a fixed predetermined number of angular directions and a good overall efficiency for a range of angular directions at the expense of increased complexity in the antenna [13].

In this paper, we demonstrate a scalable, two-branch rectifier, which is capable of maintaining a constant RF-to-dc conversion efficiency over any phase shift between the RF signals present at its input terminals and, therefore, over any angular direction. This topology is able to combine RF energy from any angular direction and convert it efficiently to dc output power. It is based on a Wilkinson power combiner, and it is scalable, employing combiner modules connected to a large number of antenna elements or subarrays and subsequently combining the output in series or parallel configuration.

In addition to RF power, combining our rectifier employs dc power combining at 2.4 GHz by optimally combining the output of two rectifiers in parallel. Our rectifier design could be easily scaled up to mmWave frequencies (i.e., 60 GHz) and miniaturized for a future 5G application. Therefore, we propose a rectifier module, which provides RF and dc power combining to achieve high conversion efficiency with minimum variation from RF signals with an arbitrary phase, thereby utilizing a nonlinear device to maintain both a high gain and an omnidirectional characteristic for a rectenna.

Some research efforts have been made in harvesting using Wilkinson combiners or dividers. In [14], a rectenna design is proposed and integrated with RFID sensors to harvest ambient power from the RF devices operating in the 2.4-GHz ISM band. The circuit consists of two diode pairs, a Wilkinson power divider, storage and bypass capacitors, and an impedance matching circuit. Measured performance for the rectifier is given and shown to be 70% efficient for high-power signals of 3 dBm. In [15], the researchers present the results of an RF energy harvester at 2.4-GHz Wi-Fi–WLAN frequency band. Wilkinson's circuit is used to combine the RF signals

from two patch antennas and supply a modified Greinacher rectifier. This dc energy is stored in a supercapacitor in order to supply on-demand self-powered sensor nodes. The maximum efficiency is measured to be 57.8% at a 6-dBm input power. In [16], a method for recycling the wasted power in the isolation resistor of a Wilkinson power combiner is presented when the input signals are not identical. A rectifier is used to replace the isolation resistor of the Wilkinson power combiner to recycle the power that would originally be dissipated in the isolation resistor. It is noticed that only one rectifier circuit is used and the application is to improve the efficiency of power amplifiers (PAs) configured as dual-phase pulse-modulated polar transmitters (PMPTs), and therefore, it does not convert the RF inputs to dc power.

Our proposed design works in the 2.4-GHz ISM band and combines two single-diode zero-bias Schottky rectifiers with a conventional Wilkinson circuit in order to be insensitive to the angle of incidence of incoming waves. One rectifier was connected at the output of the combiner. The isolation resistor in the Wilkinson power combiner was replaced by the second half-wave rectifier. To the best of our knowledge, this design is unique because it is used only for RF energy-harvesting purposes. The measured RF-to-dc efficiency of the rectifier array was calculated around 16% for in-phase input signals with an available input power of -17 dBm. When the relative phase of input signals varied from 0° to 360° , a variation in efficiency between 15.3% and 22% was observed. The preliminary results of this paper were presented in [17]. A detailed analysis of the circuit design and optimization is presented here, followed by a number of additional measurements, including efficiency versus load, frequency, and phase difference at different power input levels.

The structure of this paper is as follows. Section II provides information about the Wilkinson power combiner circuit. Section III describes the design and implementation of the RF-to-dc converter. Section IV presents the proof-of-concept experimental results using two continuous signals with different phases. Section V provides the comparison of this paper with other similar works at the same frequency band. Finally, Section VI includes concluding and future remarks.

II. WILKINSON POWER COMBINER

The conventional Wilkinson power combiner/divider [see Fig. 1(a)] was invented around 1960 by Wilkinson [18]. The combiner is ideally lossless when the two input signals are in-phase and have identical power ($P_{in,i}$), as the combiner port 3 delivers an output power of $2P_{in,i}$ to the matched output. When only one input signal with power $P_{in,i}$ exists, only $P_{in,i}/2$ of power is delivered to the output and the other half of the power is dissipated in the isolation resistor. Furthermore, when the two input signals have a phase difference, a significant amount of energy is dissipated at the resistor.

Our proposed work uses a Wilkinson combiner connected with two single-diode rectifier circuits for RF energy harvesting. One rectifier is connected at port 3, as shown in Fig. 1(b), in order to deliver the sum of the power. This design

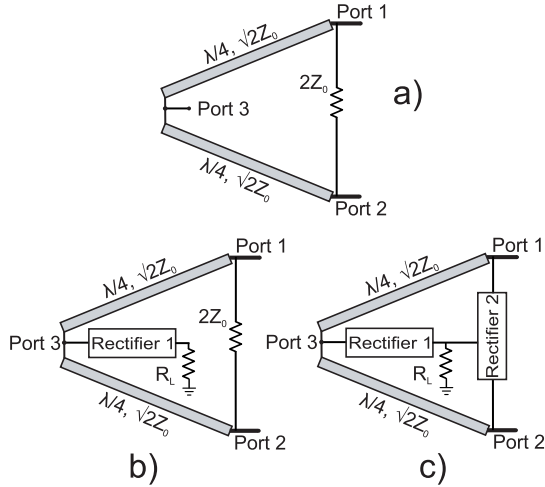

Fig. 1. Power combiner circuits with rectification capabilities. (a) Typical Wilkinson combiner circuit. (b) Wilkinson combiner circuit with a single rectifier. (c) Wilkinson combiner with two rectifier circuits. One rectifier has been installed at port 3, and the isolation resistor has been replaced with the second rectifier.

exploits the drawback with the non-in-phase input signals using the second RF-to-dc rectifier to replace the isolation resistor, as shown in Fig. 1(c). Using this novel topology, the energy that was originally going to be dissipated at the 100- Ω resistor can be captured and supplied the load of the system. The second rectifier guarantees a wide angular range at the RF inputs. The circuit is called “double” in the following text, it is particularly simple, and it can easily be fabricated using lumped components on a printed circuit board (PCB). For benchmarking purposes, a design with one rectifier and an isolation resistor was also fabricated, and it is referred to as “single.”

III. RF-TO-DC CONVERTER

A. Design

Our initial goal was to increase efficiency and decrease the complexity of the circuit. For this reason, only one diode was used in each rectifier circuit since double diode rectification circuits increase losses [19], [20]. For each rectifier, the low-cost Schottky barrier diode SMS7630-040LF from Skyworks Solutions was selected due to its low capacitance of 0.3 pF and the low forward voltage [21]. Since the maximum power transfer occurs when the circuit is matched with the input, impedance matching was performed at a particular available input power of -20 dBm for each input port. The rectifiers were matched to operate simultaneously using a common load at the output, and the layout of the rectification circuit is shown in Fig. 2. As noted earlier, the RF-to-dc converter consists of two rectifiers with their impedance matching circuits, a Wilkinson power combiner, a storage capacitor (C_1), and a load (R_L) at the output. The matching circuits reduce the reflection losses of the incoming waves, while the capacitor C_1 was introduced in order to stabilize the obtained dc voltage. Finally, the output power supplies the load R_L .

The proposed rectenna was designed and fabricated on the FR-4 substrate in order to decrease the total cost of the design.

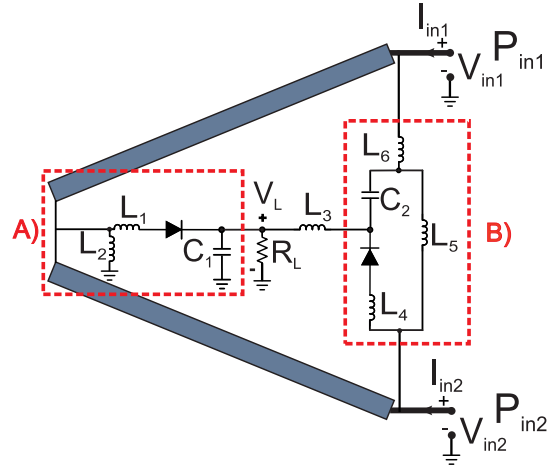

Fig. 2. Circuit of the double design. Two single rectifiers (dash rectangle) have been combined using a common load R_L .

The FR-4 characteristics were: $\epsilon_r = 4.58$, $\tan \delta = 0.022$, a copper thickness of $35 \mu\text{m}$, and a substrate height of 0.6 mm .

B. Simulation and Optimization

The converter was designed for operation at 2.4-GHz frequency, considering that the Wi-Fi, Bluetooth, as well as RFID systems work at ISM 2.4-GHz band. The design was simulated using the Keysight Technologies ADS software with harmonic-balance (HB) analysis. Initially, a fixed layout with only the microstrip traces was created and simulated electromagnetically with the method of moments at 2.4 GHz. The goal was to estimate the losses from the low-cost FR-4 substrate and copper and the electromagnetic coupling between the two input ports. Next, the layout model was imported into a schematic design, and the lumped component models were connected with the layout model. HB analysis was applied, which takes into consideration simultaneously the losses of the substrate, the conductive lines, the components, and the nonlinear behavior of the rectifiers due to the diodes. Multiobjective optimization was used during the simulation process with degrees of freedom only the inductor lumped elements (L) and the load R_L . The first optimization goal was the maximization of RF-to-dc efficiency

$$\eta = \frac{P_{\text{out}}}{P_{\text{in}}} = \frac{V_L^2/R_L}{P_{\text{in},1} + P_{\text{in},2}} \quad (1)$$

with $P_{\text{in},1,2}$ is the available power at the two input ports of the rectifier, P_{out} is the power at the load, and V_L is the voltage across the load R_L . In order to achieve better accuracy in the optimization procedure, the second goal was utilized, which was the minimization of reflection coefficient at each input port

$$\Gamma_{\text{in},i} = \frac{Z_{\text{in},i} - 50}{Z_{\text{in},i} + 50} \quad (2)$$

assuming an input impedance of 50Ω and $Z_{\text{in},i} = V_{\text{in},i}/I_{\text{in},i}$ with $i = 1, 2$. The optimization design parameters were not only the matching network components but also the value of the load at the output. Considering that in a realistic RFID

TABLE I
CIRCUIT COMPONENTS FOR THE DOUBLE DESIGN

Name	Value	SMD Package Type	Model
L_1	5.1 nH	0603	0603CS-5N1X_EU
L_2	2.2 nH	0603	0603CS-2N2X1_EU
L_3	210 nH	0603	0603CS-R21X_EU
L_4	5.6 nH	0603	0603CS-5N6X_EU
$L_{5,6}$	1.8 nH	0603	0603CS-1N8XJEU
$C_{1,2}$	100 pF	0402	-
R_L	1588 Ω	Potentiometer	-
Diode	$L_p = 0.7$ nH, $C_p = 0.25$ pF	SC-79	SMS7630-079LF

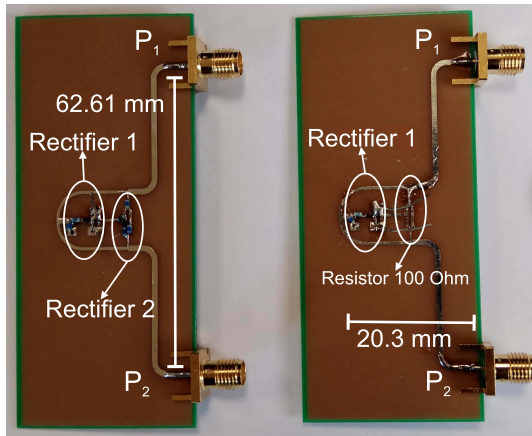

Fig. 3. Two fabricated designs on the low-cost FR-4 substrate. Left: “double” design includes two rectifiers. Right: “single” design includes one rectifier and one isolation resistor.

system, the load value is up to 50 k Ω [22], our design could be optimized for a given load value instead of an optimal one. As it is shown in Section IV, every P_{in} level has an optimum load, and thus, this approach would be suboptimum for the efficiency maximization.

After the initial optimization, the ideal lumped elements were progressively replaced by real product S-parameter models provided by the supplier (Coilcraft), and the circuit was reoptimized. The final values and the part numbers of the chip inductors and capacitors are given in Table I. The capacitances C_1 and C_2 and the power $P_{in,i}$ at both the inputs ports were fixed at 100 pF and -20 dBm, respectively. The obtained optimal lumped element values for the “double” circuit were found as $L_1 = 5.1$ nH, $L_2 = 2.2$ nH, $L_3 = 210$ nH, $L_4 = 5.6$ nH, $L_{5,6} = 1.8$ nH, and $R_L = 1588 \Omega$. For the “single” design, only the L_1 , L_2 , and C_1 components were used with the same values as “double” design. In the “single” converter, the second rectifier [see Fig. 2, B)] was replaced with the 100- Ω isolation resistor, and the optimum load was found at $R_L = 1759 \Omega$.

C. Fabrication

For validation purposes, the RF-to-dc converters were fabricated as is shown in Fig. 3. On the right, the PCB of “single” design is shown. The “double” is shown on the left and contains an extra rectifier instead of the isolation resistor in order to collect the dissipated energy. The design on the right was fabricated for comparison purposes with the design on the left, as it can be seen in Section IV.

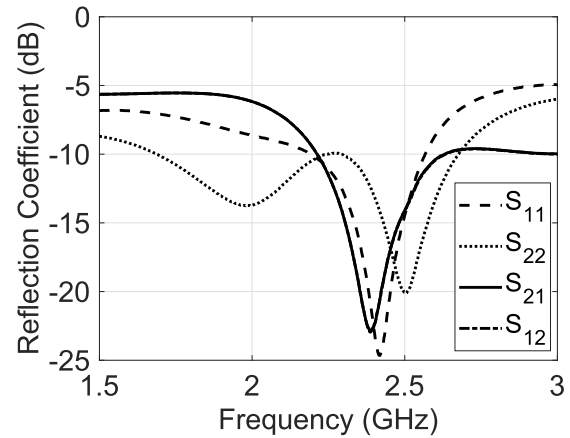

Fig. 4. S-parameters of “single” design. The VNA available input power ($P_{in,i}$) at each port was fixed at -20 dBm.

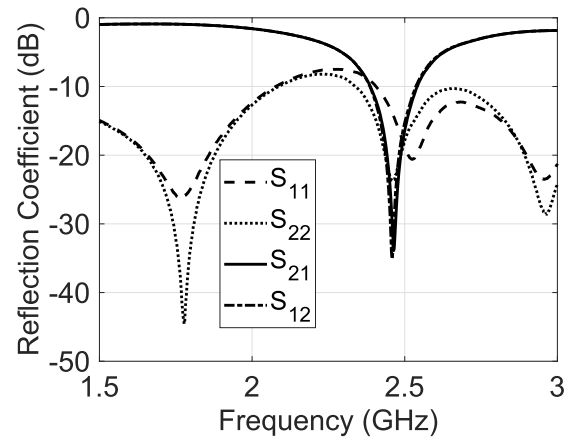

Fig. 5. S-parameters of “double” design. The VNA available input power ($P_{in,i}$) at each port was fixed at -20 dBm.

IV. EXPERIMENTAL RESULTS

A. In-Phase Input Measurements

The two converters were measured using a vector network analyzer (VNA) at frequencies of 1.5–3.5 GHz. The input signals were the carrier wave (CW) tones of VNA with $P_{in,1,2} = -20$ dBm. The measured S-parameters of the “single” and “double” designs are shown in Figs. 4 and 5, respectively. It is shown that the reflection coefficient at each port (S_{11} and S_{22}) is below -10 dB at the center frequency of 2.4 GHz.

Regarding in-phase input RF signals, a commercial Wilkinson power divider was connected to a signal generator for the efficiency measurements. The divider outputs were connected with board inputs through the two “same-length” RF cables. First, a power meter (Keysight U8487A) was connected to each cable, measuring the received power of the signal. Next, the power meter was removed, and cables were connected to the proposed “double” design. The total power P_{in} is considered as the sum of $P_{in,1}$ and $P_{in,2}$, which are the two divider output ports. A voltmeter measures the voltage across the load, which is fixed at 1588 Ω . Fig. 6 shows the measured results of η versus P_{in} for the “double” design.

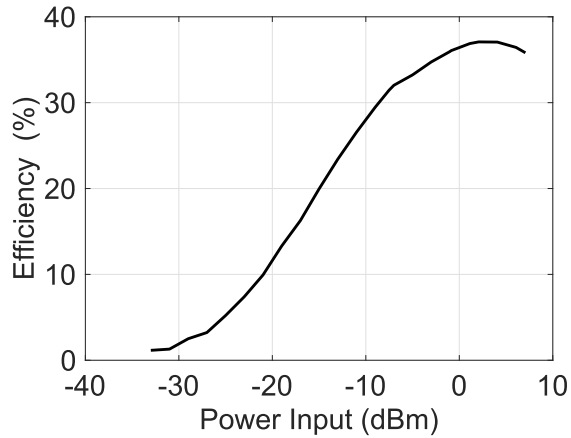

Fig. 6. Measurement rectifier efficiency of “double” design versus the available input power (P_{in}). The two input signals have the same phase at the frequency of 2.4 GHz.

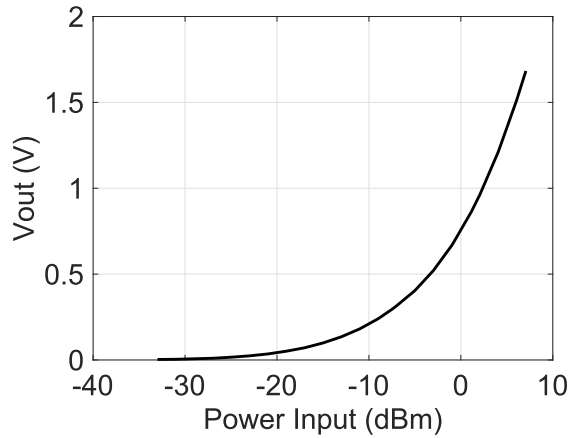

Fig. 7. Measured output voltage of “double” converter across the 1588- Ω load. The two input signals have the same phase at the frequency of 2.4 GHz.

The efficiency is equal to 29.46% and 9.93% for P_{in} equal to -9 and -21 dBm, respectively. The maximum efficiency was achieved for $P_{in} = 2$ dBm, and it was found at 37%. Fig. 7 shows the measured voltage values across the 1588- Ω load. V_L is equal with 51 mV for $P_{in} = -21$ dB and 240 mV for $P_{in} = -9$ dBm, respectively. Fig. 8 presents the relation between the efficiency and the load only for the “double” design using three power input levels, with the frequency fixed at 2.4 GHz. In this case, a commercial potentiometer was used for the load variation instead of a fixed resistor. It is obvious that there is a specific value for the load that maximizes the efficiency for each P_{in} value. More specifically, for $P_{in} = -7$ dBm and $P_{in} = 3$ dBm, maximum efficiency is equal to 27.76% and 39.3% for 1487- and 706- Ω load, respectively. For $P_{in} = -17$ dBm, the maximum efficiency occurs when $R_L \simeq 1554 \Omega$, as was expected from the simulation results. The measured efficiency versus frequency for a different P_{in} and load fixed at 1554 Ω is shown in Fig. 9. It is shown that the “double” converter operates optimally at 2.4 GHz for $P_{in} = -17$ dBm, as expected from the initial design. Also the maximum efficiency is achieved at points very close to 2.4 GHz for the rest of power levels. As can be observed from

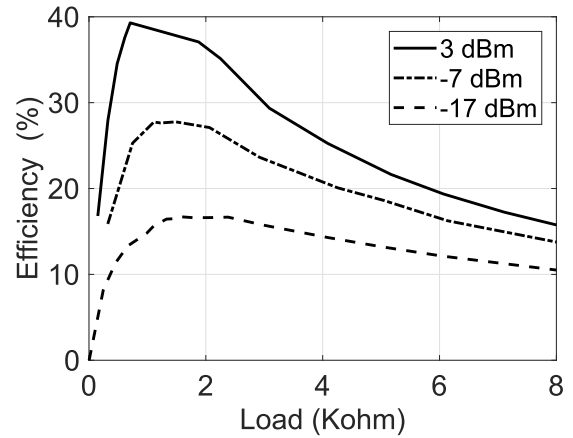

Fig. 8. Measured “double” rectifier efficiency versus load for a different available input power at 2.4 GHz.

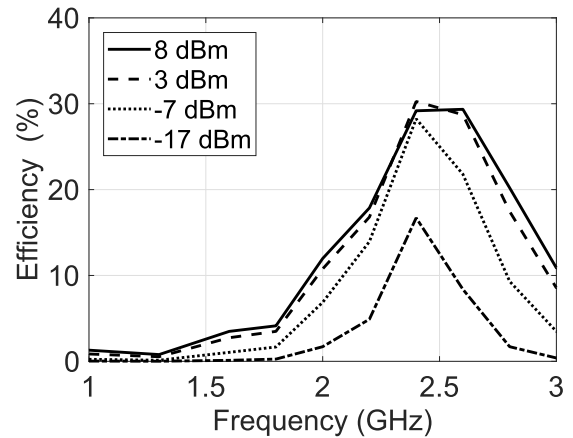

Fig. 9. Measured “double” rectifier efficiency versus frequency for different power input levels. Load is fixed at 1559 Ω .

Figs. 8 and 9, there is a nonlinear relation of the efficiency versus P_{in} , the frequency, as well as the load due to the diodes’ nonlinearities.

B. Out-of-Phase Input Measurements

Finally, the two designs were simulated and tested for input signals with different phases each one. Each board was connected with two synchronized signal generators simultaneously as shown in Fig. 10 setup. The generator outputs were connected with boards through the same RF cables that were used in the previous results. The first generator was used for phase change from 0° to 360° ; thus, at the second generator, the phase of the signal was fixed at 0° . In Fig. 10, the voltmeter and the potentiometer are also shown.

Fig. 11 shows the efficiency achieved for $P_{in} = -17$ dBm and the phase difference from 0° to 360° . The load for “double” design was fixed at 1554 Ω and for “single” at 1759 Ω . A very good agreement between simulation and measurements is observed for both the designs. For the “single” design, the efficiency is maximized when the input signals are in-phase. Moreover, the efficiency goes to zero when the phase difference is 180° and retreated periodically every 360° .

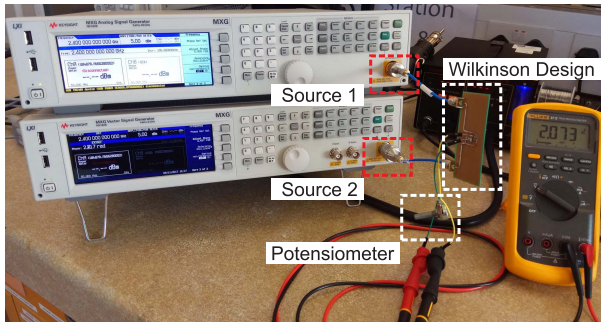

Fig. 10. Two signal generators measurement setup. The one generator has a fixed zero-phase 2.4-GHz signal. The second generator was used for the phase sweeping.

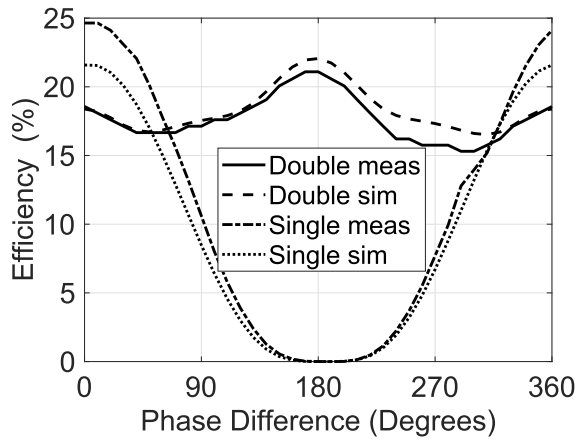

Fig. 11. Simulated and measured converter efficiency versus phase difference at the input. The input signals had a frequency of 2.4 GHz with $P_{in} = -17$ dBm.

The “double” design addresses the problem of the power dissipation on the isolation resistor when the inputs signals are out-of-phase. A constant efficiency is observed between 15.31% and 21.9% from 0° to 360° . In Fig. 12, the measured efficiency versus the phase difference for $P_{in} = 3$ dBm is shown. The optimal load for the “double” and “single” design was experimentally found at 1022 and 909 Ω , respectively, based on the data shown in Fig. 8. The topologies have similar behavior for a higher P_{in} value, as shown in Fig. 11. The maximum efficiency of “double” was measured at 39.02% at 180° , and the minimum was 26.2% at 300° . Moreover, the “single” had a maximum efficiency of 48.61% at 0° . Finally, the efficiency for $P_{in} = 8$ dBm is shown in Fig. 13. The loads for “single” and “double” designs were fixed at 653 and 774 Ω , respectively. It can be observed that although P_{in} has been increased from 3 to 8 dBm, the maximum efficiency cannot go over 40% for the “double” design and over 47.8% for the “single” design due to the breakdown effect of the diodes.

The number of diode elements in the circuit has a major influence on the output voltage of the energy harvesting circuit. Due to the fact that the diodes do not operate as ideal switches, when the number of diodes increases, the total power dissipated in the diodes increases. This has an impact on the RF-to-dc conversation efficiency, especially at low input

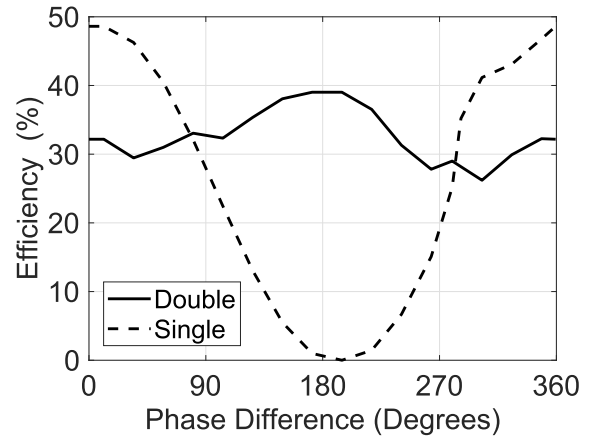

Fig. 12. Measured converter efficiency versus phase difference at the input. The input signals had a frequency of 2.4 GHz with $P_{in} = 3$ dBm.

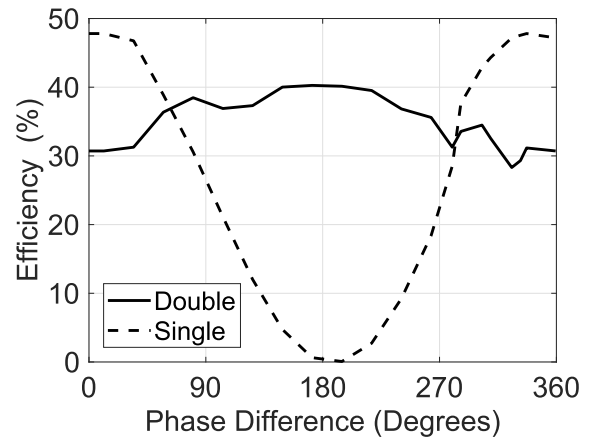

Fig. 13. Measured converter efficiency versus phase difference at the input. The input signals had a frequency of 2.4 GHz with $P_{in} = 8$ dBm.

power levels. Consequently, a rectifier circuit with one diode presents a higher efficiency than a rectifier circuit with two diodes at low input power level [19]. This is also evident in Fig. 11 when the efficiency of the “single” design is higher than the efficiency of the “double” design.

V. DISCUSSION

Table II offers the summary of achieved efficiency versus input power for various prior art designs operating at the 2.4-GHz band. We compare rectifiers/rectennas with our design for the in-phase conditions only, and however, it should be emphasized that our work focused on optimizing efficiency under non-in-phase excitation. In order to further increase the efficiency, substrates with low losses [23]–[26] have been proposed. In [23], efficiency was increased to 50% for -17.2 -dBm input power level. A circular polarized rectenna was presented in [24] with 15.3% and 11.3% efficiency for vertical and horizontal polarizations, respectively. In [25], a dual-polarized rectenna consists of a square aperture coupled patch antenna and a rectifier circuit that was optimized at 2.45 GHz with a simulated efficiency of 15.7% at -20 dBm. In [26], a rectenna is proposed that is formed by a miniatur-

TABLE II
RF-TO-DC EFFICIENCY FOR A FREQUENCY OF 2.4 GHz

Work	Type	Ph. Diff. (Deg.)	Eff. (%)	P_{in} (dBm)
[13]	Rectifier	0	43%	-10
[13]	Rectifier	0	10%	-17
[23]	Rectenna	0	50%	-17.2
[24]	Rectenna	0	38.2%	-19.2
[24]	Rectenna	0	15.3%	-9.2
[25]	Rectenna	0	15.7%	-20
[25]	Rectenna	0	42.1%	-10
[26]	Rectenna	0	24%	-17
[26]	Rectenna	0	55%	-7
[27]	Rectenna	0	37%	-25.7
[28]	Rectenna	0	31.8%	-15
This work	Rectifier	0	32%	-7
This work	Rectifier	0	18.5%	-17
This work	Rectifier	180	21.9%	-17
This work	Rectifier	300	15.3%	-17

ized second iteration Koch fractal patch antenna and a two-stage Dickson charge pump rectifier. The rectenna achieves a small size with relatively high realized gain (4 dBi) and good conversion efficiency around 24% at -17 dBm. In [27], a fully integrated remotely powered RFID chip is described working at 2.45 GHz. The necessary input power to operate the transponder is about $2.7 \mu\text{W}$. The efficiency of the rectifier circuit is about 37% for -25.7-dBm input power including the antenna effects. In [28], an optimized rectenna structure is presented, which eliminates the matching circuit and exhibits the optimal rectifier architecture. The antenna has been configured as an inductively coupled-feed dipole, and it is directly matched to the input impedance of the rectifier and can be noticed that all the above-mentioned designs provide efficient results only for in-phase signals.

In [13], a design approach for RF energy harvesting to receive more energy in a wide incident angle range is presented. A beamforming matrix and a dc power management network are used to the hybrid (RF and dc) power combining. To experimentally verify the proposed hybrid combining array performance, four suspended patch antennas were attached to the RF energy harvesting architecture. More specifically, a 4×4 Butler matrix and quadrature hybrids are used for the beamforming matrix in a hybrid power combining rectenna array. Each port of the Butler matrix with a 4×4 array antenna has a fixed peak gain at a fixed incident wave angle.

Instead of all the designs, the challenge for this paper was to design an efficient rectification circuit, working in a wide incident angle range. Our design uses the minimum number of inputs and discrete lumped elements in order to maintain a constant RF-to-dc efficiency over a wide angular range compared with the other designs of Table II.

VI. CONCLUSION AND FUTURE WORK

In this paper, we present a rectifier circuit for RF energy harvesting. Our rectifier combiner does RF power combining and dc power combining in order to achieve high conversion efficiency with minimum variation from RF signals with an arbitrary phase, thereby maintaining both a high gain and an omnidirectional characteristic for a rectenna. A prototype was

fabricated on the low-cost FR-4 substrate, and measurements were agreed with simulations.

Nowadays, one of the major research goals is to overcome fundamental challenges related to the miniaturization of electronic circuits in order to scale them up in mmWave frequencies. The mmWave communications is a key candidate technology for future 5G cellular networks. This is mainly due to the availability of large spectrum resources at higher frequencies, which leads to much higher data rates. Transferring wireless energy, in mmWave frequencies, seems attractive for future applications where base stations with directional beamforming capabilities could supply miniaturized low-power devices such as RFID tags. The base station/reader could align its narrow beams with the tags in order to supply them with power, and the same signals could also be used for the communication links. The proposed system could be miniaturized and applied on passive RFID tag implementations in order to collect energy from multiple directions. Our novel circuit could also be combined with a retrodirective antenna array such as a Van Atta array in order to reradiate the signal back to the reader [29]–[31] and, at the same time, harvest a maximum amount of power independently of the angle of arrival of the incoming reader signal.

ACKNOWLEDGMENT

The authors would like to thank Lloyd's Register Foundation (LRF) and the International Consortium in Nanotechnology (ICON). The authors would also like to thank all members of the Microwaves and Antenna Engineering Research Group, Heriot-Watt University, Edinburgh, U.K., for their help in various steps throughout this paper.

REFERENCES

- [1] N. Shinohara, "Power without wires," *IEEE Microw. Mag.*, vol. 12, no. 7, pp. S64–S73, Dec. 2011.
- [2] M. Piñuela, P. D. Mitcheson, and S. Lucyszyn, "Ambient RF energy harvesting in urban and semi-urban environments," *IEEE Trans. Microw. Theory Techn.*, vol. 61, no. 7, pp. 2715–2726, Jul. 2013.
- [3] K. Niotaki, A. Collado, A. Georgiadis, S. Kim, and M. M. Tentzeris, "Solar/Electromagnetic energy harvesting and wireless power transmission," *Proc. IEEE*, vol. 102, no. 11, pp. 1712–1722, Nov. 2014.
- [4] S. Kim *et al.*, "Ambient RF energy-harvesting technologies for self-sustainable standalone wireless sensor platforms," *Proc. IEEE*, vol. 102, no. 11, pp. 1649–1666, Nov. 2014.
- [5] W. C. Brown, "The history of power transmission by radio waves," *IEEE Trans. Microw. Theory Techn.*, vol. MTT-32, no. 9, pp. 1230–1242, Sep. 1984.
- [6] C. R. Valenta and G. D. Durgin, "Harvesting wireless power: Survey of energy-harvester conversion efficiency in far-field, wireless power transfer systems," *IEEE Microw. Mag.*, vol. 15, no. 4, pp. 108–120, Jun. 2014.
- [7] S. D. Assimonis, S.-N. Daskalakis, and A. Bletsas, "Sensitive and efficient RF harvesting supply for batteryless backscatter sensor networks," *IEEE Trans. Microw. Theory Techn.*, vol. 64, no. 4, pp. 1327–1338, Apr. 2016.
- [8] K. Kotani, A. Sasaki, and T. Ito, "High-efficiency differential-drive CMOS rectifier for UHF RFIDs," *IEEE J. Solid-State Circuits*, vol. 44, no. 11, pp. 3011–3018, Nov. 2009.
- [9] J. Kimionis, A. Georgiadis, and M. M. Tentzeris, "Millimeter-wave backscatter: A quantum leap for gigabit communication, RF sensing, and wearables," in *IEEE MTT-S Int. Microw. Symp. Dig.*, Honolulu, HI, USA, Jun. 2017, pp. 812–815.
- [10] T.-H. Lin, S. Daskalakis, A. Georgiadis, and M. M. Tentzeris, "Achieving fully autonomous system-on-package designs: An embedded-on-package 5G energy harvester within 3D printed multilayer flexible packaging structures," in *IEEE MTT-S Int. Microw. Symp. Dig.*, Boston, MA, USA, Jun. 2019.

- [11] J. Hester and M. M. Tentzeris, "A mm-wave ultra-long-range energy-autonomous printed RFID-enabled van-atta wireless sensor: At the crossroads of 5G and IoT," in *IEEE MTT-S Int. Microw. Symp. Dig.*, Honolulu, HI, USA, Jun. 2017, pp. 1557–1560.
- [12] B. R. Marshall and G. D. Durgin, "Staggered pattern charge collection: Antenna technique to improve RF energy harvesting," in *Proc. IEEE Int. Conf. RFID*, Malaysia, May 2013, pp. 30–35.
- [13] D.-J. Lee, S.-J. Lee, I.-J. Hwang, W.-S. Lee, and J.-W. Yu, "Hybrid power combining rectenna array for wide incident angle coverage in RF energy transfer," *IEEE Trans. Microw. Theory Techn.*, vol. 65, no. 9, pp. 3409–3418, Sep. 2017.
- [14] U. Olgun, C.-C. Chen, and J. L. Volakis, "Low-profile planar rectenna for batteryless RFID sensors," in *Proc. IEEE Antennas Propag. Soc. Int. Symp.*, Toronto, ON, Canada, Sep. 2010, pp. 1–4.
- [15] F. Alneyadi, M. Alkaabi, S. Alketbi, S. Hajraf, and R. Ramzan, "2.4 GHz WLAN RF energy harvester for passive indoor sensor nodes," in *Proc. IEEE Int. Conf. Semiconductor Electron. (ICSE)*, Malaysia, Aug. 2014, pp. 471–474.
- [16] T. H. Wang and J. H. Chen, "Power recycling using Wilkinson power combiner with pulsewidth modulation," in *Proc. IEEE Int. Symp. Radio-Freq. Integr. Tech. (RFIT)*, Seoul, South Korea, Sep. 2017, pp. 223–225.
- [17] S. N. Daskalakis, G. Goussetis, and A. Georgiadis, "A 2.4 GHz rectifier insensitive to the angle of incidence of incoming waves," in *Proc. 2nd URSI Atlantic Radio Sci. Meeting (AT-RASC)*, Meloneras, Spain, May/June 2018, pp. 1–4.
- [18] E. J. Wilkinson, "An N-way hybrid power divider," *IEEE IRE Trans. Microw. Theory Techn.*, vol. MTT-8, no. 1, pp. 116–118, Jan. 1960.
- [19] P. Nintanavongsa, U. Muncuk, D. R. Lewis, and K. R. Chowdhury, "Design optimization and implementation for RF energy harvesting circuits," *IEEE J. Emerg. Sel. Topics Circuits Syst.*, vol. 2, no. 1, pp. 24–33, Mar. 2012.
- [20] A. Boaventura, A. Collado, N. B. Carvalho, and A. Georgiadis, "Optimum behavior: Wireless power transmission system design through behavioral models and efficient synthesis techniques," *IEEE Microw. Mag.*, vol. 14, no. 2, pp. 26–35, Mar./Apr. 2013.
- [21] Skyworks. (2018). *SMS7630 Surface-Mount Mixer Detector Schottky Diodes, Product Manual*. [Online]. Available: http://www.skyworksinc.com/uploads/documents/Surface_Mount_Schottky_Diodes_200041AD.pdf
- [22] N. Pournoori, M. W. A. Khan, L. Ukkonen, and T. Björninen, "RF energy harvesting system with RFID-enabled charge storage monitoring," in *Proc. IEEE Conf. RFID Techn. Appl. (RFID-TA)*, Macau, China, Sep. 2018, pp. 1–5.
- [23] H. Sun, Y.-X. Guo, M. He, and Z. Zhong, "Design of a high-efficiency 2.45-GHz rectenna for low-input-power energy harvesting," *IEEE Antennas Wireless Propag. Lett.*, vol. 11, pp. 929–932, 2012.
- [24] A. Georgiadis, G. V. Andia, and A. Collado, "Rectenna design and optimization using reciprocity theory and harmonic balance analysis for electromagnetic (EM) energy harvesting," *IEEE Antennas Wireless Propag. Lett.*, vol. 9, pp. 444–446, 2010.
- [25] G. A. Vera, A. Georgiadis, A. Collado, and S. Via, "Design of a 2.45 GHz rectenna for electromagnetic (EM) energy scavenging," in *Proc. IEEE Radio Wireless Symp. (RWS)*, New Orleans, LA, USA, Mar. 2010, pp. 61–64.
- [26] U. Olgun, C.-C. Chen, and J. L. Volakis, "Wireless power harvesting with planar rectennas for 2.45 GHz RFIDs," in *Proc. URSI Int. Symp. Electromagn. Theory (EMTS)*, Berlin, Germany, Aug. 2010, pp. 329–331.
- [27] J.-P. Curty, N. Joehl, C. Dehollain, and M. J. Declercq, "Remotely powered addressable UHF RFID integrated system," *IEEE J. Solid-State Circuits*, vol. 40, no. 11, pp. 2193–2202, Nov. 2005.
- [28] Y.-S. Chen and C.-W. Chiu, "Maximum achievable power conversion efficiency obtained through an optimized rectenna structure for RF energy harvesting," *IEEE Trans. Antennas Propag.*, vol. 65, no. 5, pp. 2305–2317, Mar. 2017.
- [29] R. Y. Miyamoto and T. Itoh, "Retrodirective arrays for wireless communications," *IEEE Microw. Mag.*, vol. 3, no. 1, pp. 71–79, Mar. 2002.
- [30] J. Céspedes, F. Giuppi, A. Collado, and A. Georgiadis, "A retro-directive UHF RFID tag on paper substrate," in *Proc. IEEE Conf. RFID Techn. Appl. (RFID-TA)*, Nice, France, Nov. 2012, pp. 263–266.
- [31] B. D. Braaten, S. Asif, S. Khan, J. Hansen, and D. L. Ewert, "A compact printed Van Atta Array with zero-phase CRLH transmission lines," in *Proc. IEEE Int. Symp. Antennas Propag. USNC/URSI Nat. Radio Sci. Meeting*, Vancouver, BC, Canada, Jul. 2015, pp. 1856–1857.



Spyridon Nektarios Daskalakis (S'12) was born in Heraklion, Greece, in 1991. He received the Engineering Diploma degree (Hons.) and the M.Sc. degree in electrical and computer engineering from the Technical University of Crete (TUC), Chania, Greece, in 2014 and 2016, respectively. He is currently pursuing the Ph.D. degree at the School of Engineering and Physical Sciences, Heriot-Watt University, Edinburgh, U.K.

His current research interests include low-power, low-cost wireless sensor networks and energy harvesting. Particularly, he focuses on backscatter radio communication, battery-less sensors, low-cost software-defined radio, environmental sensing, and RF energy harvesting.

Mr. Daskalakis has been a member of the IEEE Microwave Theory and Techniques Society, the IEEE Council on RFID, and the IEEE Sensors Council. He was the recipient of a Fellowship Award from Clinton Global Initiative University, USA, in 2014, the Onassis Foundation (graduate studies 2015/2016 scholarship), the Lloyd's Register Foundation (LRF), and the International Consortium in Nanotechnology (ICON). He was a recipient of two short-term scientific mission grants from the COST Action IC1301 WiPE of the Centre Tecnològic de Telecomunicacions de Catalunya, Castelldefels, Barcelona, Spain, in 2015, and the School of Electrical and Computer Engineering, Georgia Institute of Technology, Atlanta, GA, USA, in 2016. He was also a recipient of the IEEE Microwave Theory and Techniques Society (MTT-S) Graduate Fellowship in 2019.



Apostolos Georgiadis (S'94-M'02-SM'08) was born in Thessaloniki, Greece. He received the B.S. degree in physics and the M.S. degree in telecommunications from the Aristotle University of Thessaloniki, Thessaloniki, in 1993 and 1996, respectively, and the Ph.D. degree in electrical engineering from the University of Massachusetts, Amherst, MA, USA, in 2002.

In 2002, he joined Global Communications Devices, North Andover, MA, USA, as a Systems Engineer, where he was involved in CMOS transceivers for wireless network applications. In 2003, he joined Bermai, Inc., Minnetonka, MN, USA, as an RF/Analog Systems Architect. In 2005, he joined the University of Cantabria, Santander, Spain, as a Juan de la Cierva Fellow Researcher. In 2006, he was a Consultant for Bitwave Semiconductor, Lowell, MA, USA. He collaborated with ACORDE S.A., Santander, where he was involved in the design of integrated CMOS VCOs for ultra-wideband applications. In 2007, he joined the Technological Telecommunications Center of Catalonia (CTTC), Castelldefels, Spain, as a Senior Researcher of communications subsystems, where he was a Group Leader with the Microwave Systems and Nanotechnology Department from 2013 to 2016. In 2016, he joined Heriot-Watt University, Edinburgh, U.K., as an Associate Professor. He has authored more than 180 papers in peer-reviewed journals and international conferences. His current research interests include energy harvesting and wireless power transmission, radio-frequency identification (RFID) technology, active antennas and phased-array antennas, inkjet and 3-D printed electronics, and millimeter-wave systems.

Dr. Georgiadis is currently an EU Marie Curie Global Fellow. He is also a member of the IEEE MTT-S TC-24 RFID Technologies (past Chair) and the IEEE MTT-S TC-26 Wireless Energy Transfer and Conversion. He was a recipient of the Fulbright Scholarship for graduate studies at the University of Massachusetts in 1996. In 2016, his proposal for inkjet/3-D printed millimeter-wave systems received the Bell Labs Prize, third place among more than 250 proposals recognizing ideas that "change the game" in the field of information and communications technologies. He was the General Chair of the 2011 IEEE RFID-TA Conference and the General Co-Chair of the 2011 IEEE MTT-S IMWS on Millimeter Wave Integration Technologies. He is also the Chair of the URSI Commission D: Electronics and Photonics and an AdCom member of the IEEE Council on RFID and has served as the Vice President of conferences. He was an Associate Editor of the *IET Microwaves, Antennas & Propagation* journal, *IEEE MICROWAVE AND WIRELESS COMPONENTS LETTERS*, and the *IEEE RADIO FREQUENCY IDENTIFICATION (RFID) VIRTUAL JOURNAL*. He serves as an Associate Editor for the *IEEE JOURNAL OF RFID*. He is also the founder and the Editor-in-Chief of the *Wireless Power Transfer* journal (Cambridge Univ. Press). He is a Distinguished Lecturer of the IEEE Council on RFID.



George Goussetis (S'99–M'02–SM'12) received the Diploma degree in electrical and computer engineering from the National Technical University of Athens, Athens, Greece, in 1998, the B.Sc. degree (Hons.) in physics from University College London (UCL), London, U.K., in 2002, and the Ph.D. degree from the University of Westminster, London, in 2002.

In 1998, he joined Space Engineering, Rome, Italy, as an RF Engineer, and the Wireless Communications Research Group, University of Westminster, London, U.K., as a Research Assistant, in 1999. From 2002 to 2006, he was a Senior Research Fellow with Loughborough University, Loughborough, U.K. He was a Lecturer (Assistant Professor) with Heriot-Watt University, Edinburgh, U.K., from 2006 to 2009, and a Reader (Associate Professor) with Queen's University Belfast, Belfast, U.K., from 2009 to 2013. In 2013, he joined Heriot-Watt University, as a Reader and became a Professor in 2014, where he currently directs the Institute of Sensors Signals and Systems. He has authored or coauthored over 500 peer-reviewed papers, 5 book chapters, and 1 book and holds 4 patents. His current research interests include the areas of microwave and antenna components and subsystems.

Dr. Goussetis was the recipient of a Research Fellowship from the Onassis Foundation in 2001, a Research Fellowship from the Royal Academy of Engineering, U.K., from 2006 to 2011, and the European Marie-Curie Experienced Researcher Fellowship from 2011 to 2012 and from 2014 to 2017. He was a co-recipient of the 2011 European Space Agency Young Engineer of the Year Prize, the 2011 EuCAP Best Student Paper Prize, the 2012 EuCAP Best Antenna Theory Paper Prize, and the 2016 Bell Labs Prize. He has served as an Associate Editor for IEEE ANTENNAS AND WIRELESS PROPAGATION LETTERS.



Manos M. Tentzeris (S'89–M'98–SM'03–F'10) received the Diploma degree (*magna cum laude*) in electrical and computer engineering from the National Technical University of Athens, Athens, Greece, and the M.S. and Ph.D. degrees in electrical engineering and computer science from the University of Michigan, Ann Arbor, MI, USA.

He was a Visiting Professor with the Technical University of Munich, Munich, Germany, in 2002, a Visiting Professor with the Georgia Tech Research Institute–Ireland, Athlone, Ireland, in 2009, and a Visiting Professor with the Laboratory for Analysis and Architecture of Systems–Centre national de la recherche scientifique, Toulouse, France, in 2010. He also heads the ATHENA Research Group (20 researchers), Riverside, CA, USA. He has served as the Head of the GT-ECE Electromagnetics Technical Interest Group, the Georgia Electronic Design Center Associate Director for RFID Sensors Research, the Georgia Tech NSF-Packaging Research Center Associate Director for RF research, and the RF Alliance Leader. He is currently the Ken Byers Professor of flexible electronics with the School of Electrical and Computer Engineering, Georgia Institute of

Technology, Atlanta, GA, USA. He has authored or coauthored more than 650 papers in refereed journals and conference proceedings, 5 books, and 25 book chapters. He has helped develop academic programs in 3-D/inkjet-printed RF electronics and modules, flexible electronics, origami and morphing electromagnetics, highly integrated/multilayer packaging for RF and wireless applications using ceramic and organic flexible materials, paper-based radio-frequency identification (RFID) and sensors, wireless sensors and biosensors, wearable electronics, “green” electronics, energy harvesting and wireless power transfer, nanotechnology applications in RF, microwave MEMs, and SOP-integrated (UWB, multiband, mmW, conformal) antennas. He has given more than 100 invited talks to various universities and companies all over the world.

Dr. Tentzeris is a Fellow of the Electromagnetic Academy, a member of the URSI-Commission D, the MTT-15 Committee, and the Technical Chamber of Greece, and an Associate Member of EuMA. He was a recipient/co-recipient of the 1997 Best Paper Award of the International Hybrid Microelectronics and Packaging Society, the 2000 NSF CAREER Award, the 2001 ACES Conference Best Paper Award, the 2002 International Conference on Microwave and Millimeter-Wave Technology Best Paper Award in Beijing, China, the 2002 Georgia Institute of Technology–ECE Outstanding Junior Faculty Award, the 2003 NASA Godfrey “Art” Anzic Collaborative Distinguished Publication Award, the 2003 IBC International Educator of the Year Award, the 2003 IEEE CPMT Outstanding Young Engineer Award, the 2004 IEEE TRANSACTIONS ON ADVANCED PACKAGING Commendable Paper Award, the 2006 IEEE MTT Outstanding Young Engineer Award, the 2006 Asia-Pacific Microwave Conference Award, the 2007 IEEE AP-S Symposium Best Student Paper Award, the 2007 IEEE MTT-S IMS Third Best Student Paper Award, the 2007 ISAP Poster Presentation Award, the 2009 IEEE TRANSACTIONS ON COMPONENTS AND PACKAGING TECHNOLOGIES Best Paper Award, the 2009 E. T. S. Walton Award from the Irish Science Foundation, the 2010 Georgia Institute of Technology Senior Faculty Outstanding Undergraduate Research Mentor Award, the 2010 IEEE Antennas and Propagation Society Piergiorgio L. E. Uslenghi Letters Prize Paper Award, the iCMG Architecture Award of Excellence, the 2011 International Workshop on Structural Health Monitoring Best Student Paper Award, the 2012 FiDiPro Award in Finland, the 2013 IET Microwaves, Antennas and Propagation Premium Award, the 2014 Georgia Institute of Technology ECE Distinguished Faculty Achievement Award, the 2014 IEEE RFID-TA Best Student Paper Award, the 2015 IET Microwaves, Antennas and Propagation Premium Award, the 2016 Bell Labs Award Competition Third Prize, and the 2017 Georgia Institute of Technology Outstanding Achievement in Research Program Development Award. He was the TPC Chair of the Chair of the 2005 IEEE CEM-TD Workshop and the IEEE IMS 2008 Symposium. He is also the Vice-Chair of the RF Technical Committee (TC16) of the IEEE CPMT Society. He is also the founder and the Chair of the RFID Technical Committee (TC24) of the IEEE MTT-S and the Secretary/Treasurer of the IEEE Council on RFID (C-RFID). He is also an Associate Editor of the IEEE TRANSACTIONS ON MICROWAVE THEORY AND TECHNIQUES, the IEEE TRANSACTIONS ON ADVANCED PACKAGING, and the *International Journal of Antennas and Propagation*. He served as one of the IEEE MTT-S Distinguished Microwave Lecturers from 2010 to 2012. He is one of the IEEE CRFID Distinguished Lecturers.